

HSS

HSS: Humbucker on the bridge and two single coils (middle and neck)

Overview

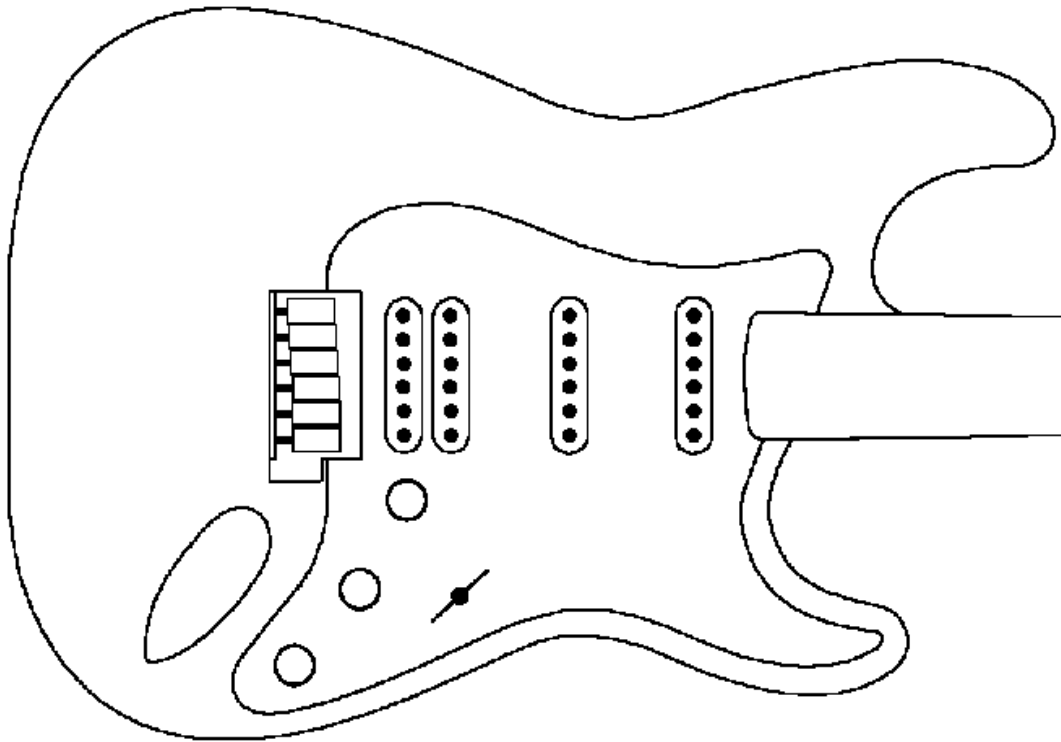

HSS1. Standard switching, no Humbucker splitting, Megaswitch S

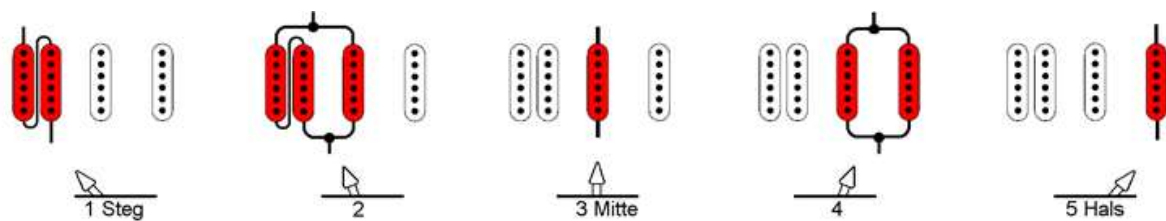

HSS2. Humbucker splitting via pickup selection switch, Megaswitch S

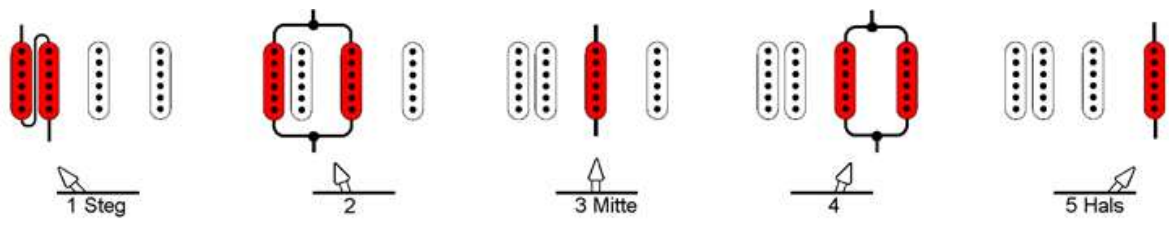

HSS3. Humbucker splitting via pickup selection switch, Megaswitch S

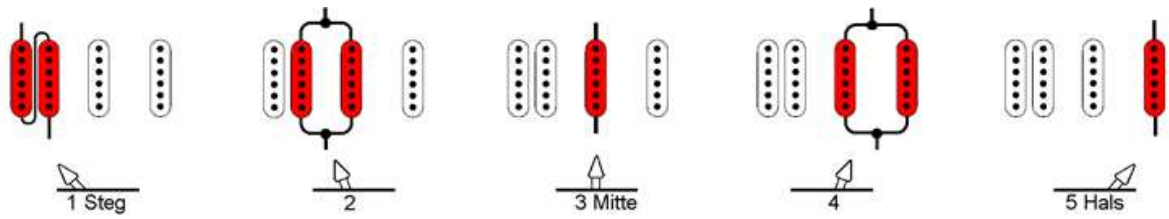

HSS4. New combinations with Megaswitch E

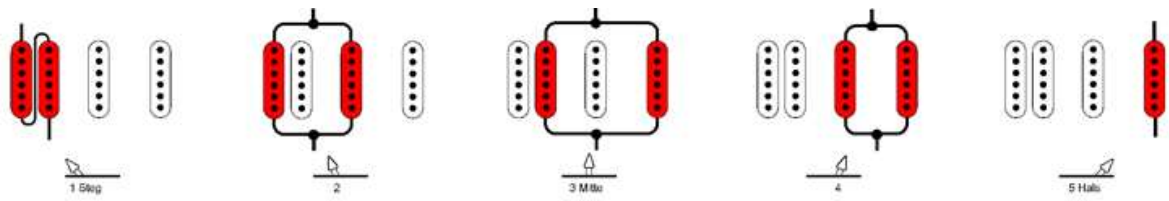

HSS5. New combinations with Megaswitch E

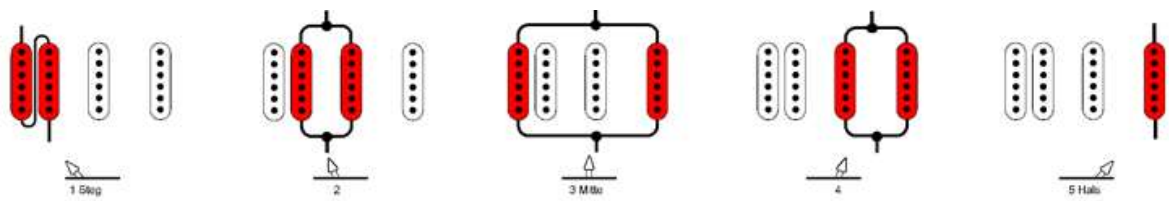

Detail drawing

HSS1. Standard switching, no Humbucker splitting, Megaswitch S

On some Stratocaster versions the bridge single coil is replaced by a Humbucker. In switching position 1 this creates a fuller sound with less brightness in the high end, more warmth in the mids and louder basses. A Megaswitch S is used here. If a buzz-free sound is required in position 4, both single coils must have opposing magnetic polarity.

Switching functions:

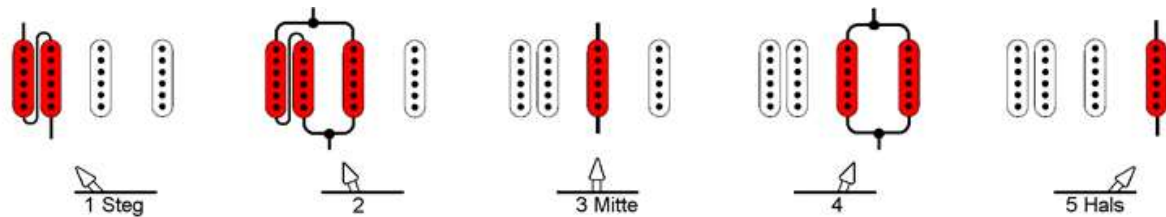

Electrical switching principle:

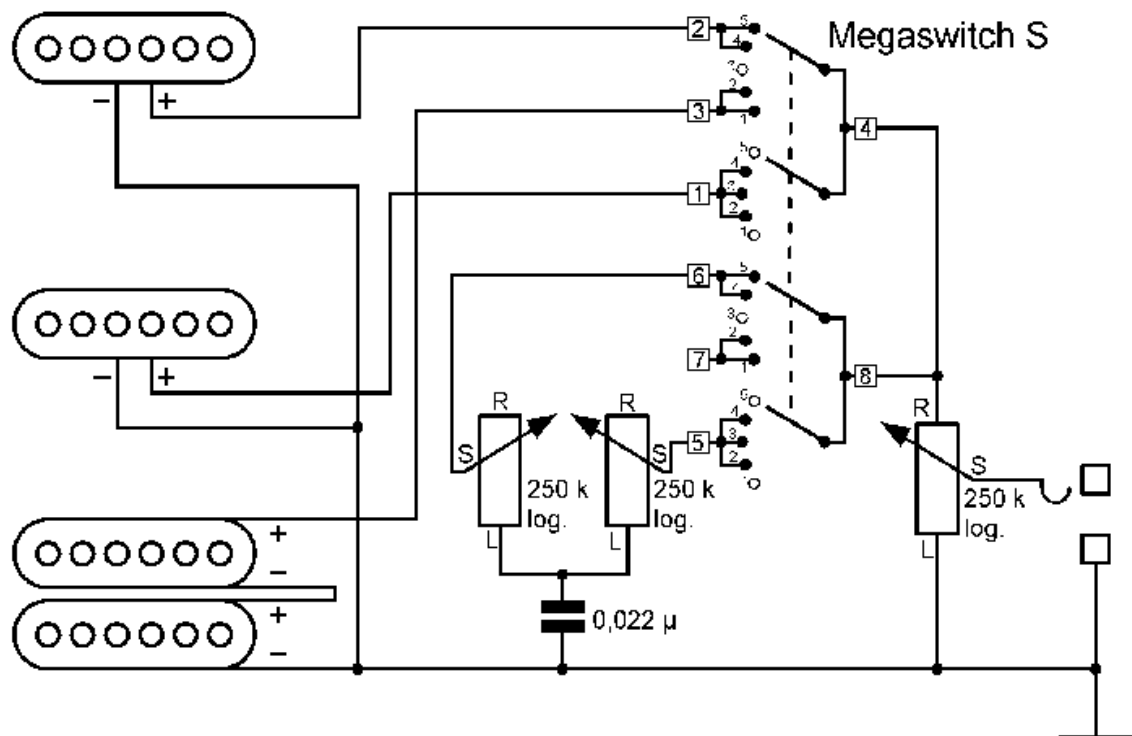

Wiring diagram:

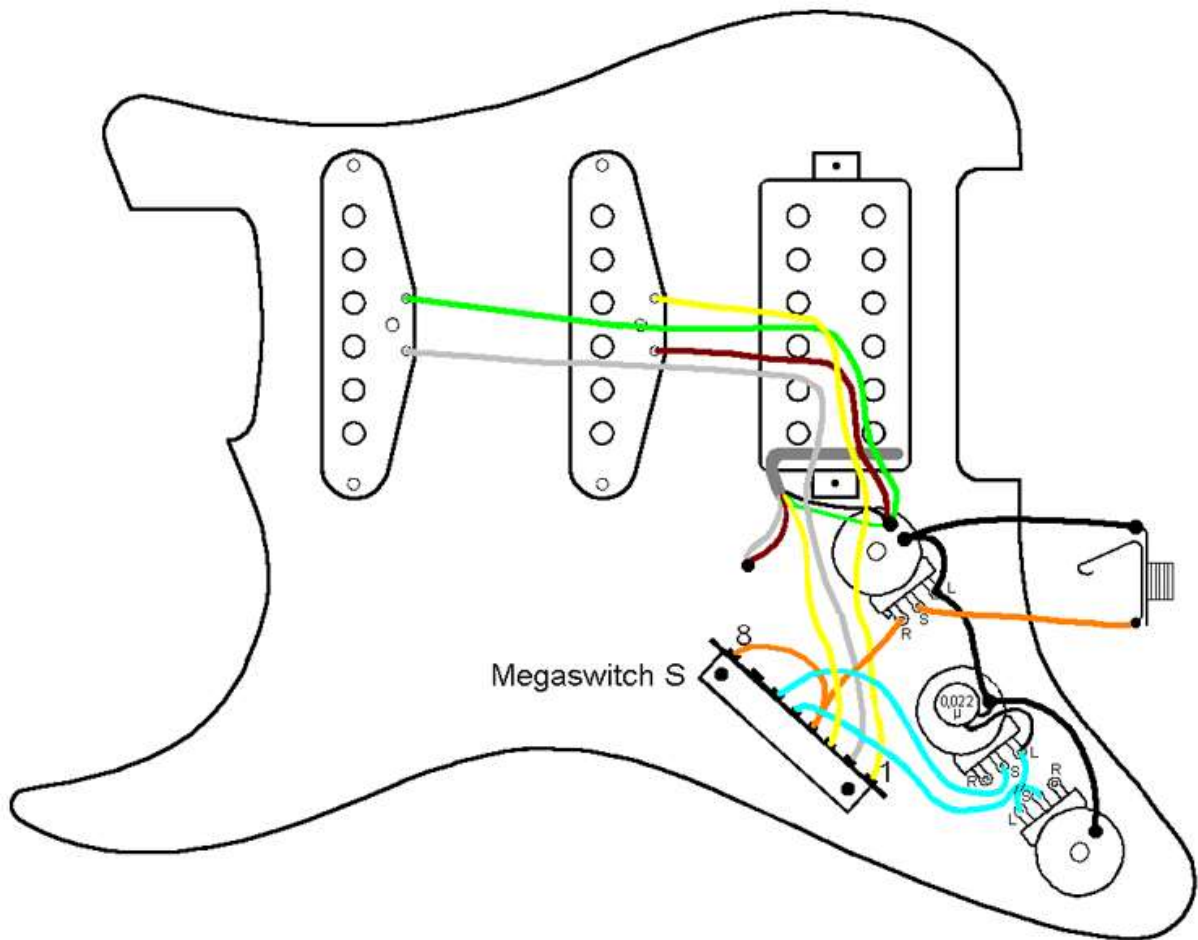

Connections:

Positions

- 1 bridge humbucker
- 2 bridge and mid parallel
- 3 mid
- 4 mid and neck parallel
- 5 neck

Connections

- 1 mid hot wire
 - 2 neck hot wire
 - 3 bridge hot wire
 - 4 to 8, output
 - 5 tone pot mid
 - 6 tone pot neck
 - 7 -
 - 8 to 4, output
- ground all three cold wires

HSS2. Humbucker splitting via pickup selection switch, Megaswitch S

This is a variation on the HSS1 switching system. In position 2, the Humbucker is split; the outer coil remains in operating mode and the inner coil is short-circuited. This also works with the Megaswitch S. If a buzz-free sound is required in positions 2 and 4, the following magnetic polarity (from the bridge to the neck) is necessary: NS-S-N or SN-N-S.

Switching functions:

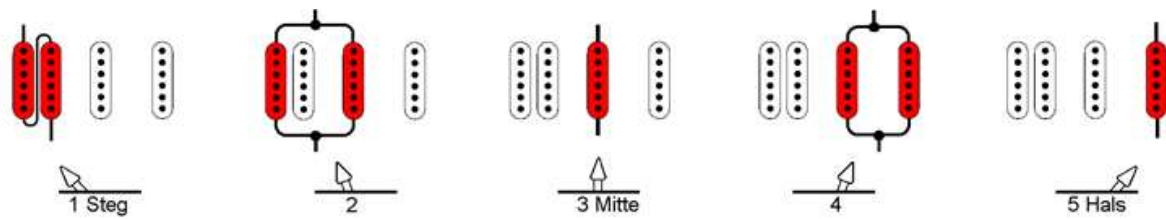

Electrical switching principle:

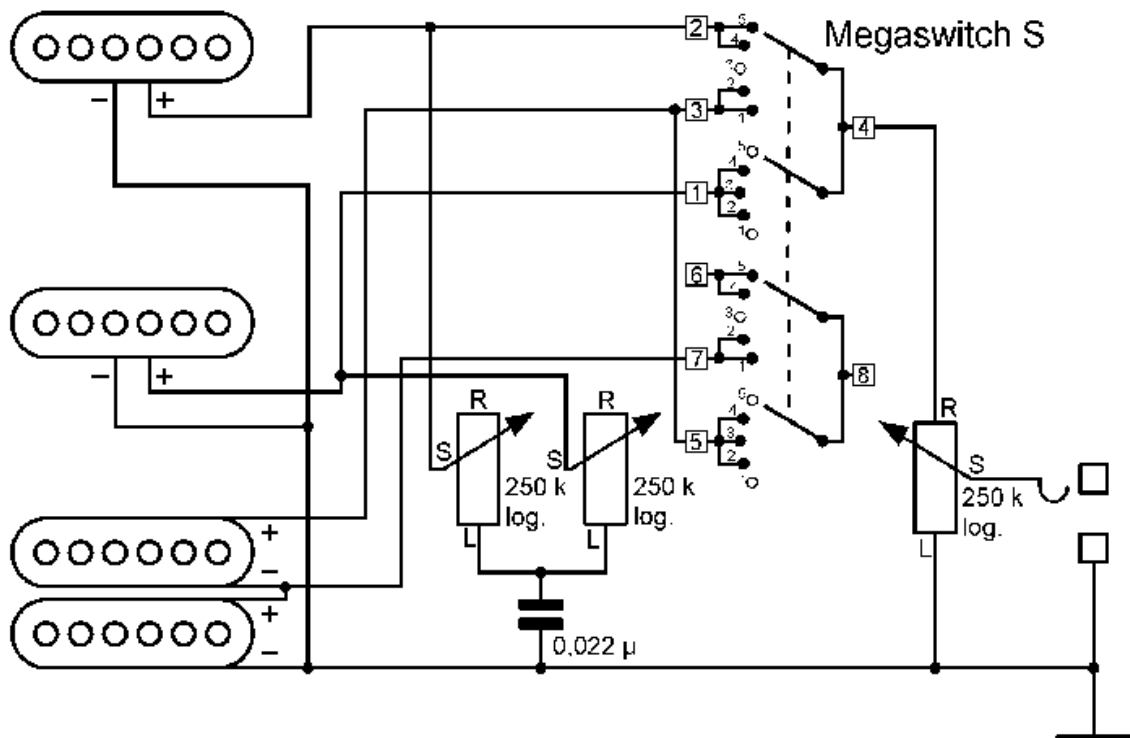

Wiring diagram:

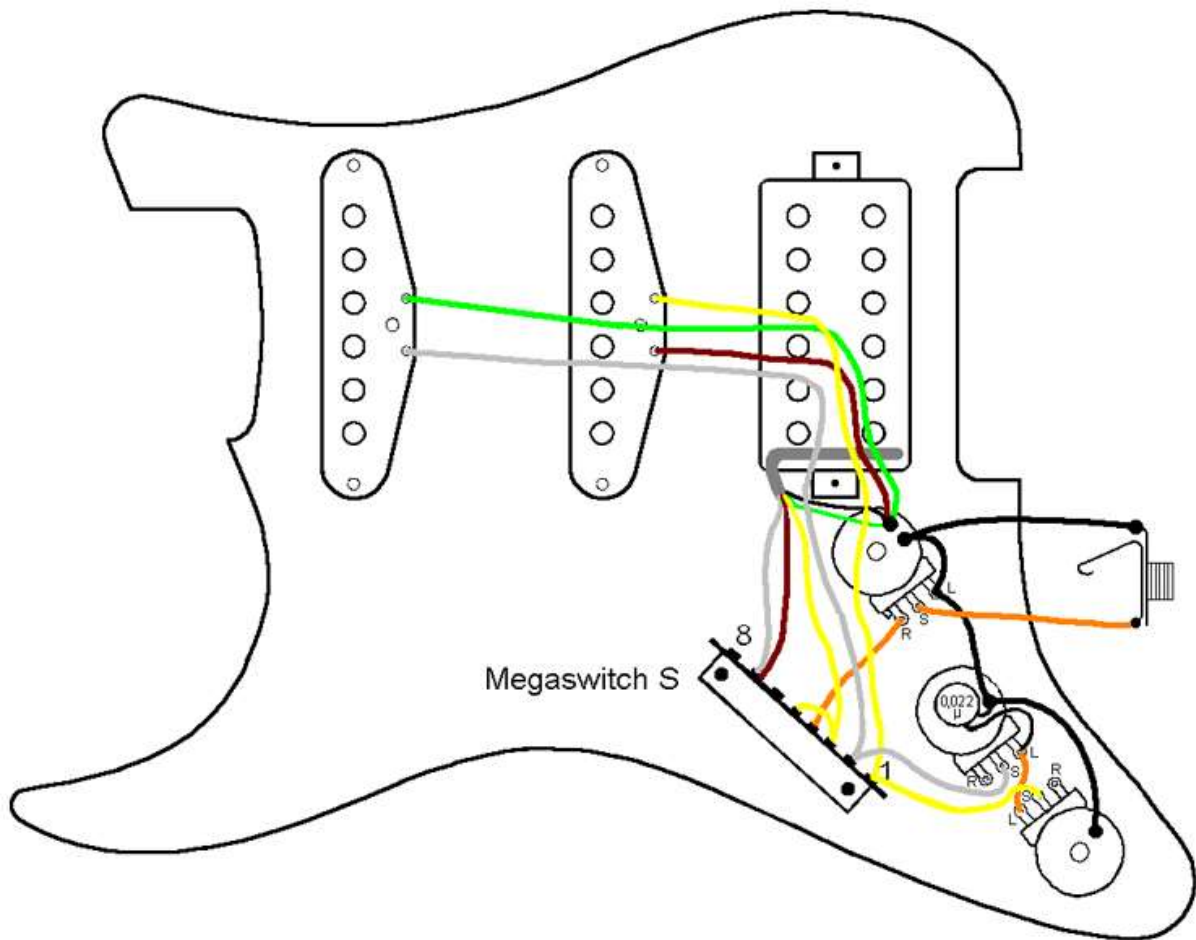

Connections:

Positions

- 1 bridge humbucker
- 2 bridge outer coil and mid parallel
- 3 mid
- 4 mid and neck parallel
- 5 neck

Connections

- 1 mid hot wire
- 2 neck hot wire
- 3 to 5, bridge hot wire inner coil
- 4 output
- 5 to 3, bridge hot wire inner coil
- 6 -
- 7 bridge outer coil hot wire and inner coil cold wire
- 8 -
- ground: bridge cold wire outer coil, mid and neck cold wire

HSS3. Humbucker splitting via pickup selection switch, Megaswitch S

This is a slight variation on the HSS2 switching system. Similar to the HSS2, the Humbucker is split in position 2. Here, the inner coil remains in operating mode. The coil closest to the bridge is short-circuited onto the earth/ground. This also functions with the Megaswitch S. If a buzz-free sound is required in positions 2 and 4, the following magnetic polarity (from the bridge to the neck) is required: NS-N-S or SN-S-N.

Switching functions:

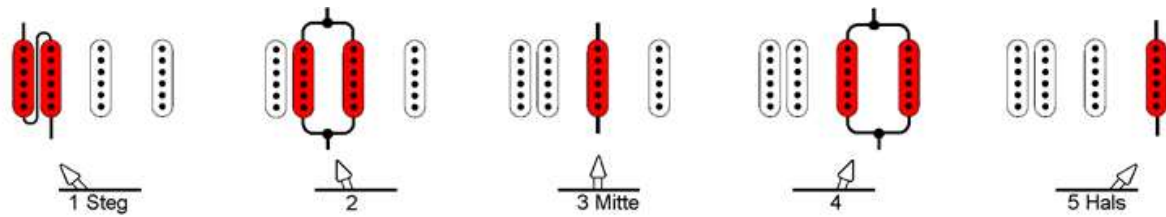

Electrical switching principle:

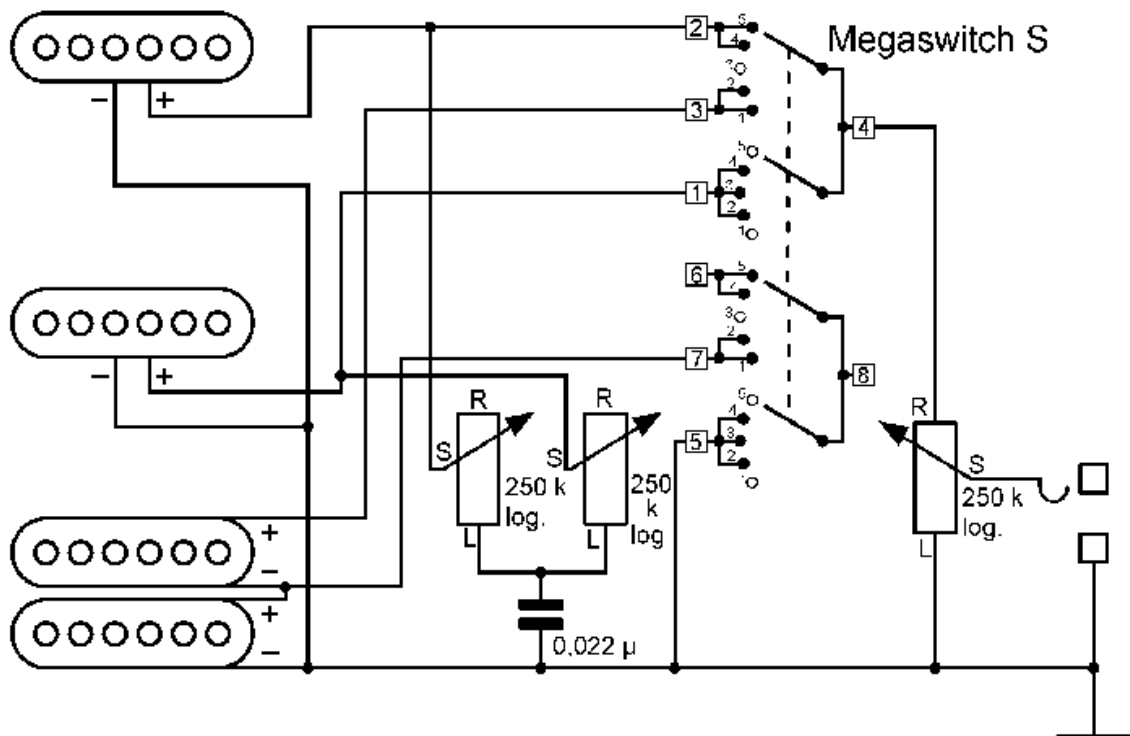

Wiring diagram:

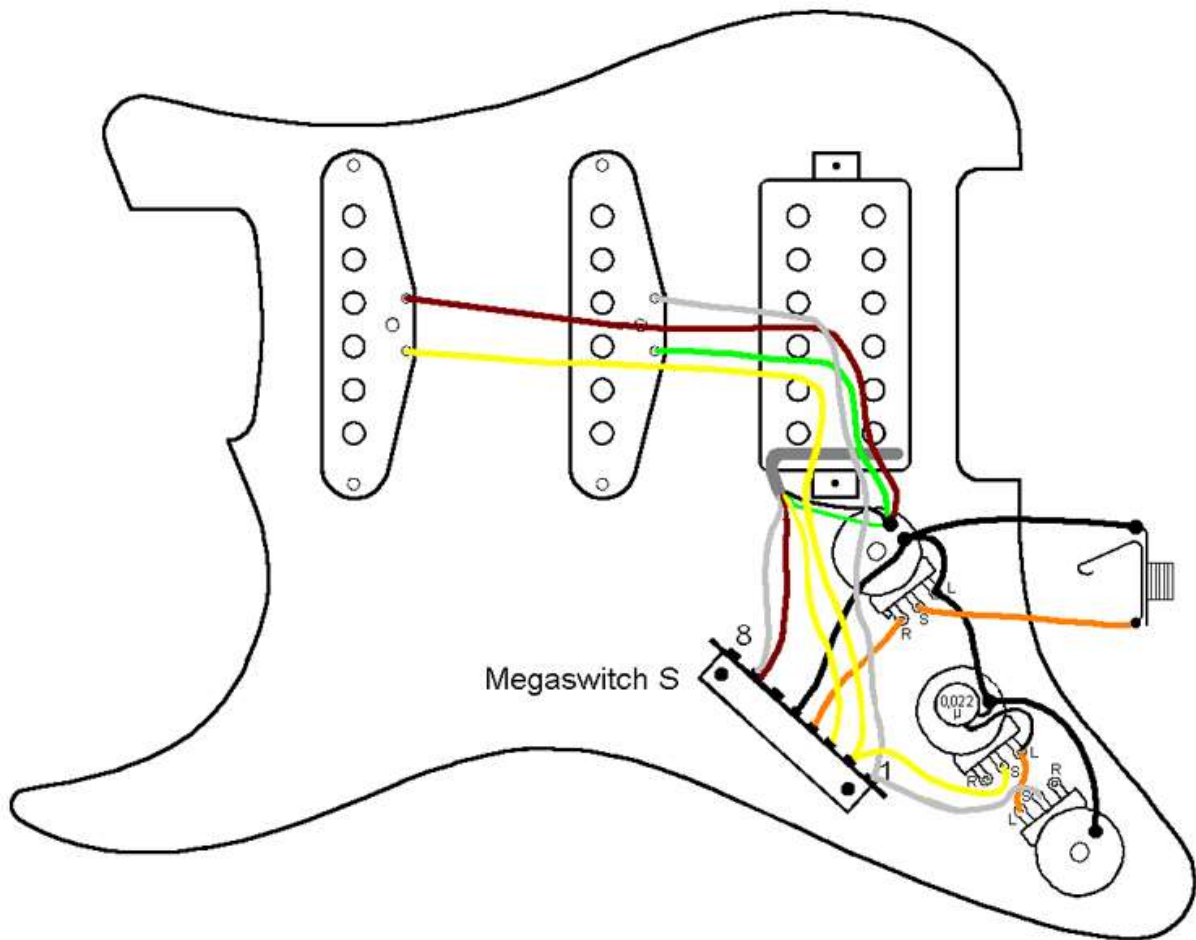

Connections:

Positions

- 1 bridge humbucker
- 2 bridge inner coil and mid parallel
- 3 mid
- 4 mid and neck parallel
- 5 neck

Connections

- 1 mid hot wire
- 2 neck hot wire
- 3 bridge hot wire inner coil
- 4 output
- 5 ground
- 6 -
- 7 bridge outer coil hot wire and inner coil cold wire
- 8 -
- ground: 5, bridge cold wire outer coil, mid and neck cold wire

HSS4. New combinations with Megaswitch E

With this switching system, the neck and the bridge pickups in position 3 are in operating mode, although the latter (the bridge pickup) is split. The inner coil remains in operating mode and the outer coil is open. In position 2 the Humbucker is split; the outer coil remains in operating mode and the inner coil is short-circuited. This enables a buzz-free sound in positions 1, 2, 3 and 4. The magnetic orientation of the coils (from the bridge to the neck) is required: NS-S-N or SN-N-S. Here, the Megaswitch E is used.

Switching functions:

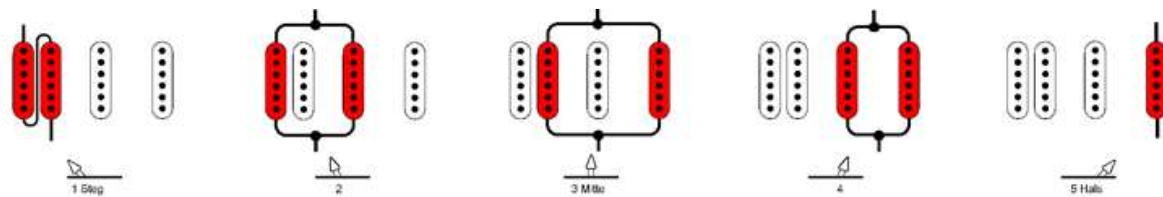

Electrical switching principle:

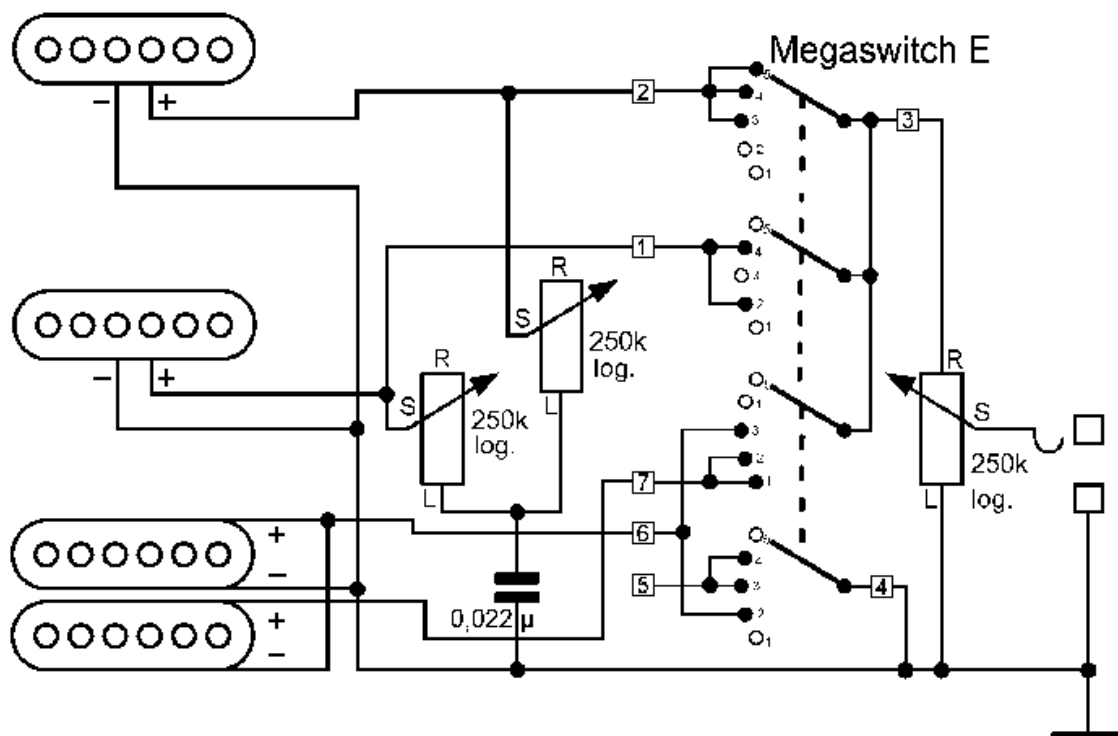

Wiring diagram:

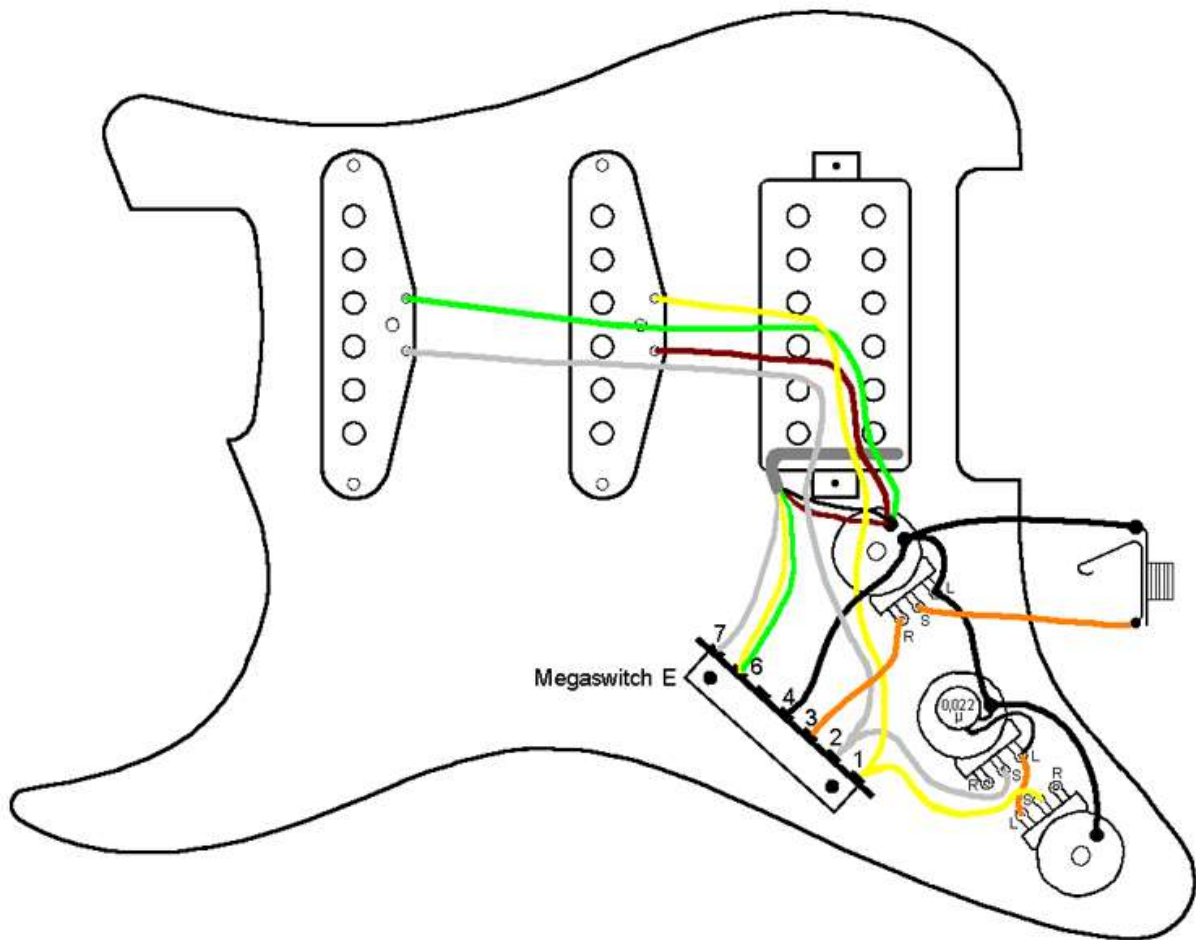

Connections:

Positions

- 1 bridge humbucker
- 2 bridge outer coil and mid parallel
- 3 bridge inner coil and neck
- 4 mid and neck parallel
- 5 neck

Connections

- 1 mid hot wire
 - 2 neck hot wire
 - 3 output
 - 4 ground
 - 5 -
 - 6 bridge hot wire inner coil and cold wire outer coil
 - 7 bridge hot wire outer coil
- ground: 4, all three cold wires

HSS5. New combinations with Megaswitch E

This is a slight variation on the HSS4 switching system. In position 3 the neck and the bridge pickups are in operating mode, although the latter is split. The outer coil remains in operating mode and the inner coil is open. In position 2 the Humbucker is also split, although here, the inner coil remains in operating mode and the outer coil is short-circuited. This enables a buzz-free sound in positions 1, 2, 3 and 4. The magnetic orientation of the coils (from the bridge to the neck) is required: NS-N-S or SN-S-N. Here, the Megaswitch E is used.

Switching functions:

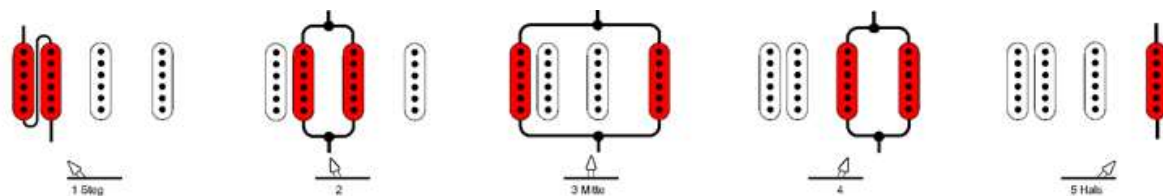

Electrical switching principle:

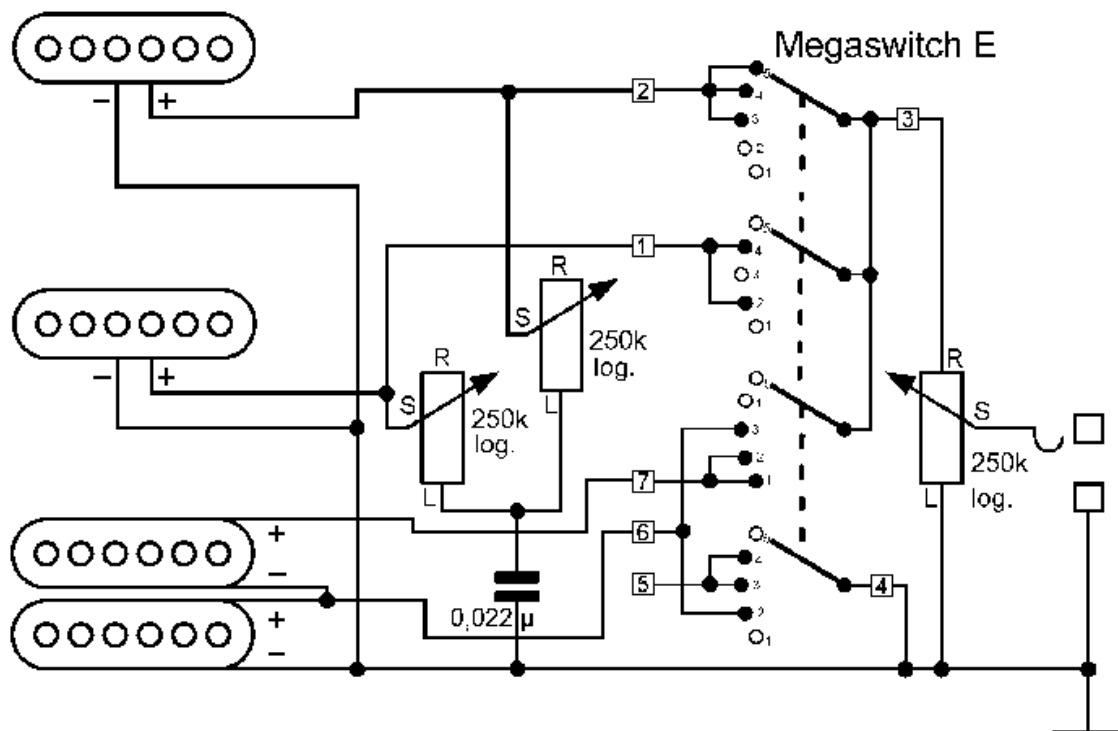

Wiring diagram:

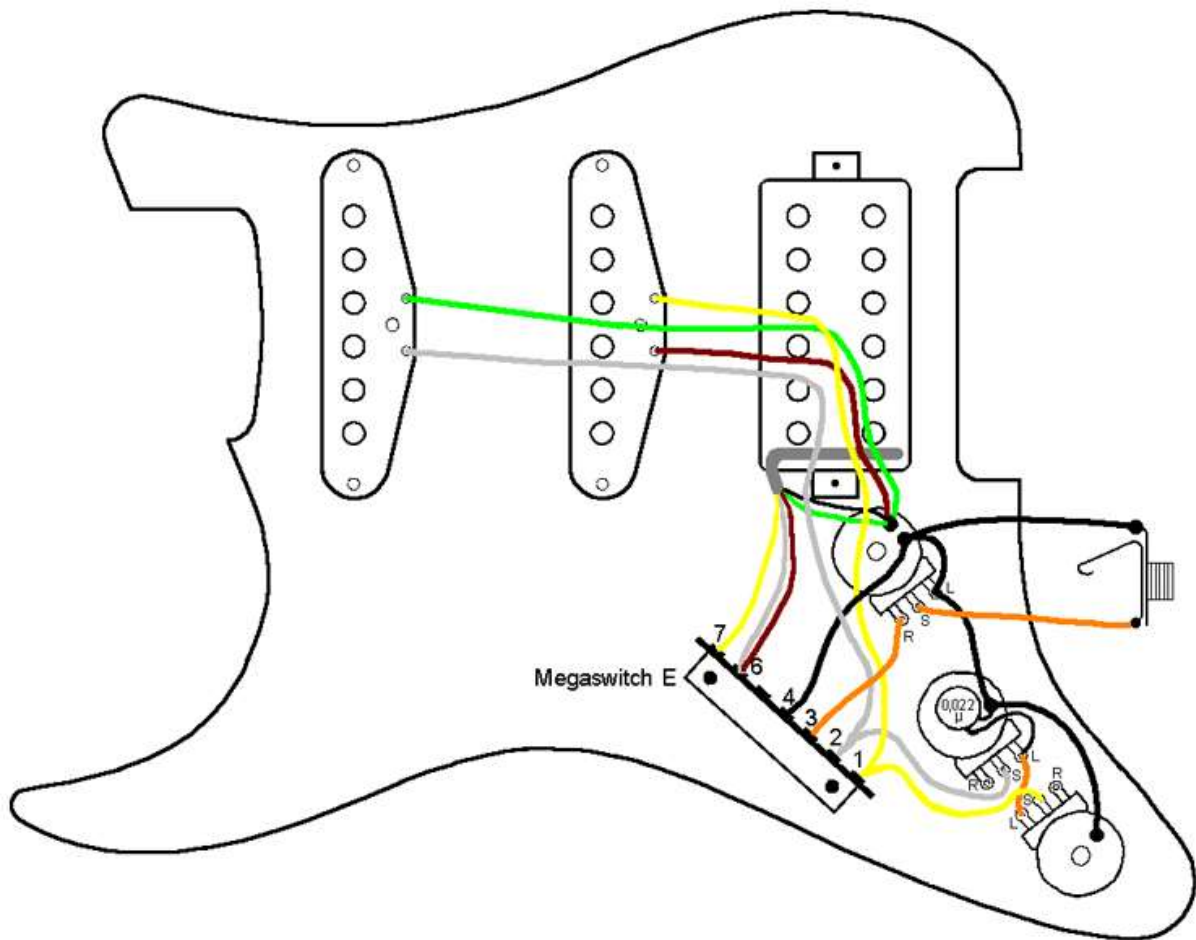

Connections:

Positions

- 1 bridge humbucker
- 2 bridge inner coil and mid parallel
- 3 bridge outer coil and neck
- 4 mid and neck parallel
- 5 neck

Connections

- 1 mid hot wire
 - 2 neck hot wire
 - 3 output
 - 4 ground
 - 5 -
 - 6 bridge hot wire outer coil and cold wire inner coil
 - 7 bridge hot wire inner coil
- ground: 4, bridge cold wire outer coil, mid and neck cold wires