

SH

SH: Single coil on the bridge, Humbucker on the neck

Overview

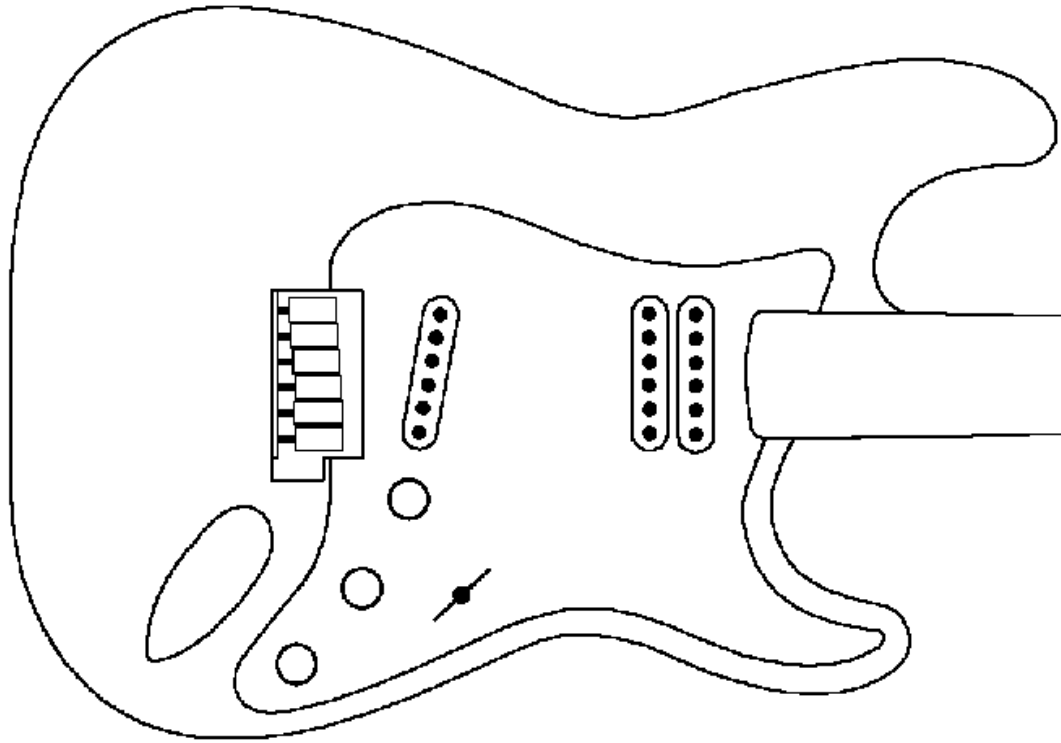

SH1. Standard switching with 3 positions, no splitting, Megaswitch T

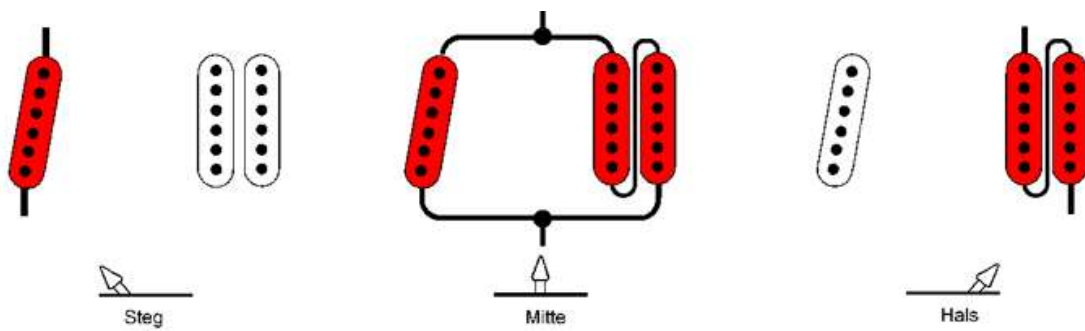

SH2. Five positions with Humbucker splitting, outer coil, Megaswitch E+

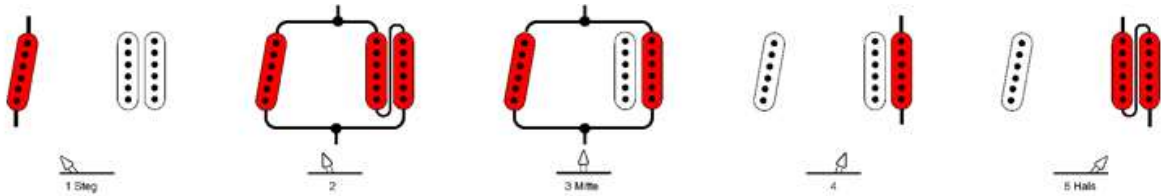

SH3. Five positions with Humbucker splitting, inner coil, Megaswitch E+

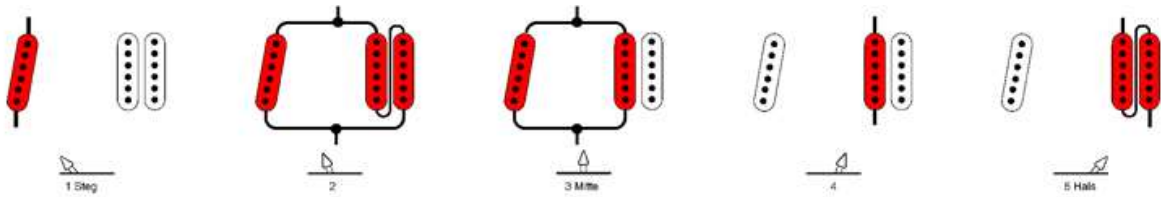

SH4. Five positions with switching in series, Humbucker splitting, outer coil, Megaswitch M

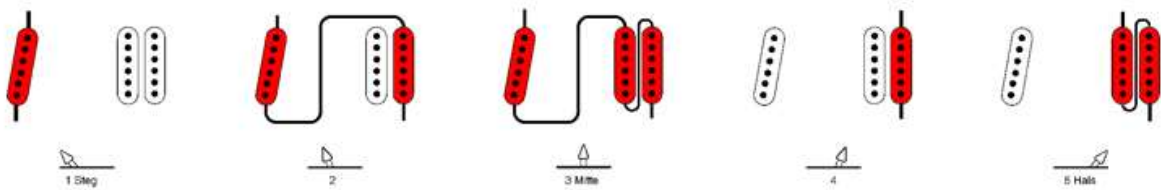

SH5. Five positions with switching in series, Humbucker splitting, inner coil, Megaswitch M

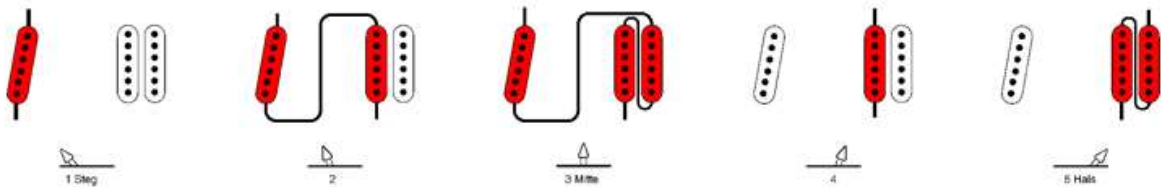

Detail drawing

SH1. Standard switching with 3 positions, no splitting, Megaswitch T

This is the simplest standard switching system for guitars that have a single coil on the bridge and Humbucker on the neck. The switch has 3 positions and operates the bridge both parallel, and the neck. Each has its own tone control. The Megaswitch T is ideal for this application.

Switching functions:

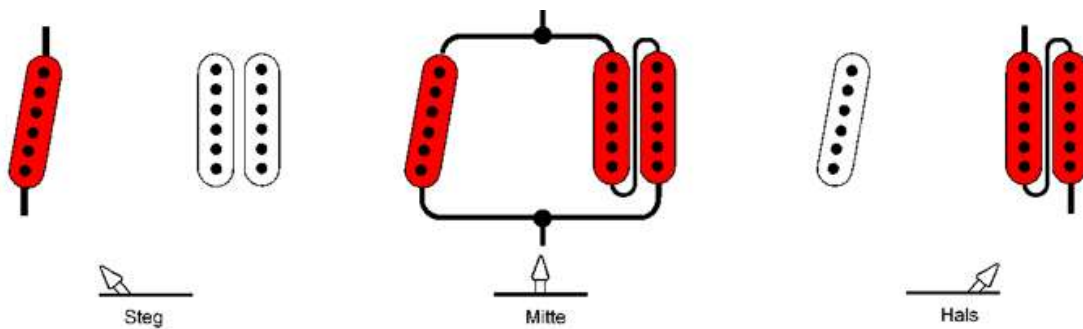

Electrical switching principle:

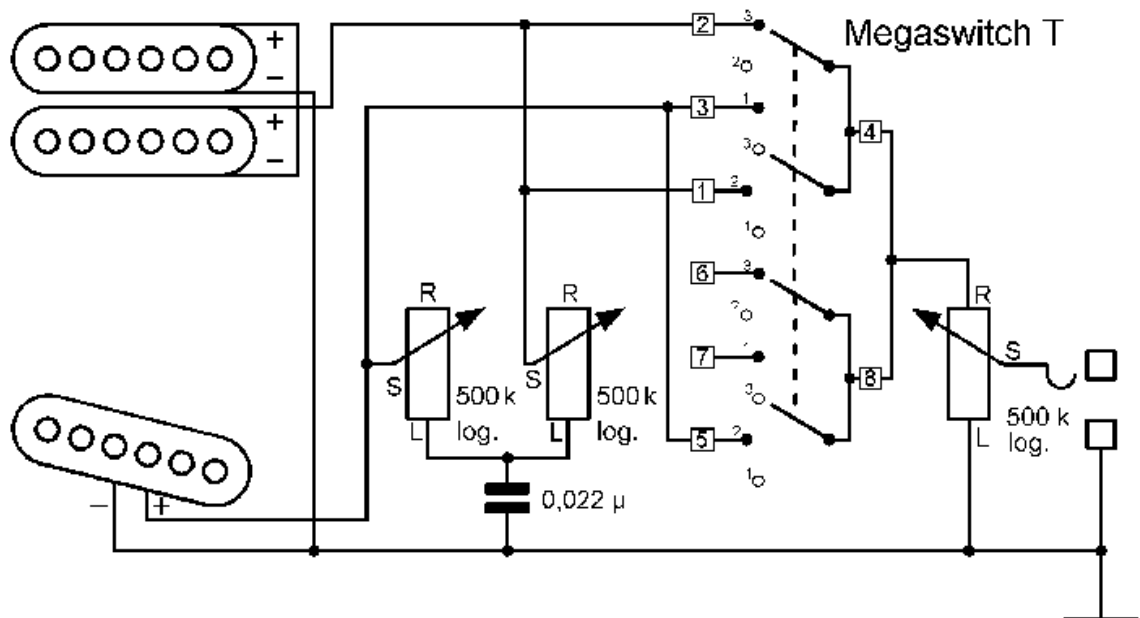

Wiring diagram:

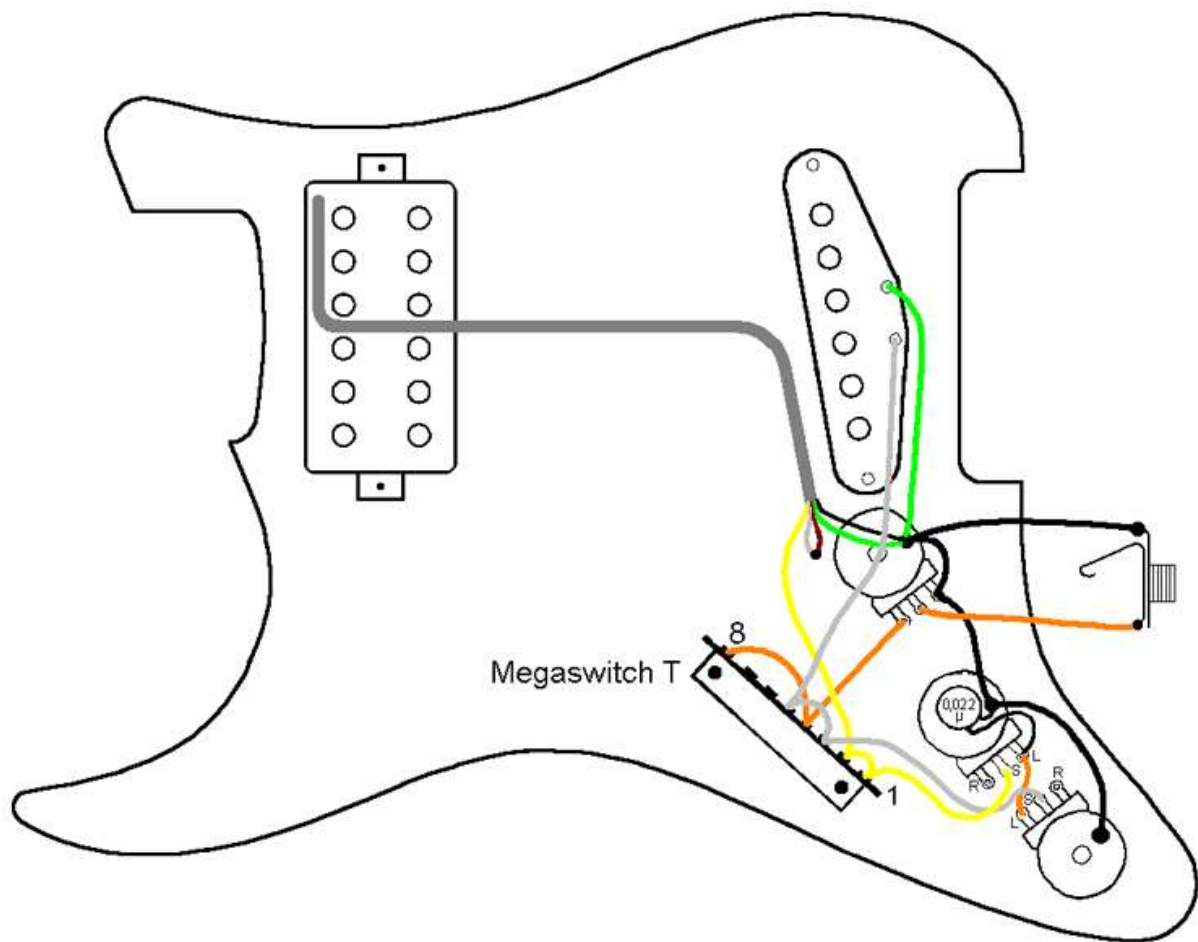

Connections:

Positions

- 1 bridge
- 2 both parallel
- 3 neck

Connections

- 1 to 2 neck hot wire
- 2 to 1 neck hot wire
- 3 to 5, bridge hot wire
- 4 to 8, output
- 5 to 3, bridge hot wire
- 6 -
- 7 -
- 8 to 4, output
- ground: both cold wires

SH2. Five positions with Humbucker splitting, outer coil, Megaswitch E+

This switching system is for guitars with a single coil on the bridge and a Humbucker on the neck. The Humbucker can be split while the outer coil remains active. The inner coil is short-circuited. The Megaswitch E+ is ideal for this purpose. Position 3 is buzz-free when the magnetic polarity is configured as follows: S-SN or N-NS.

Switching functions:

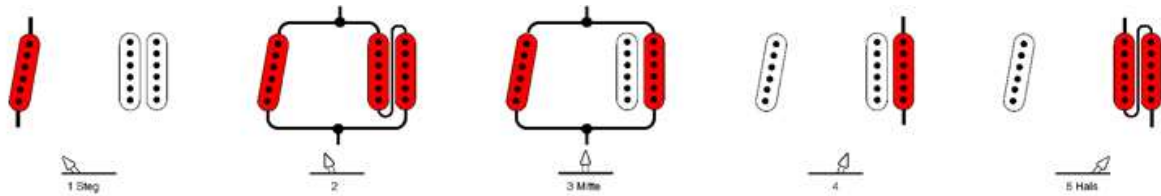

Electrical switching principle:

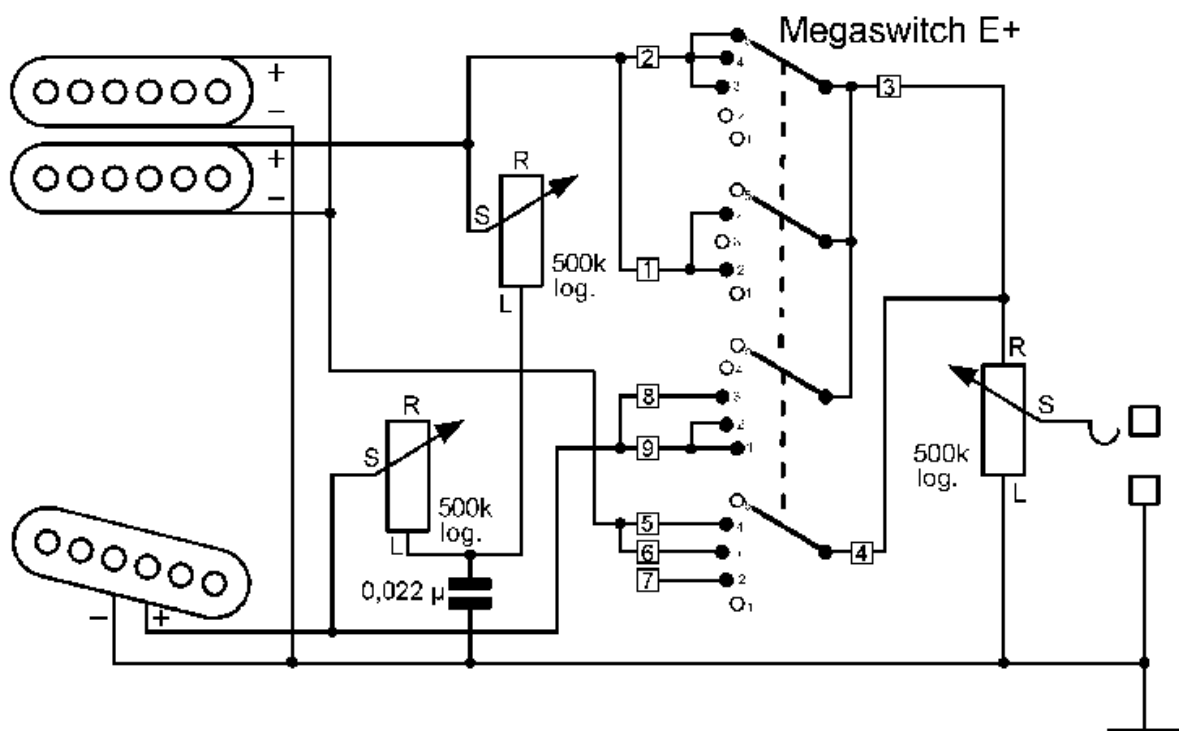

Wiring diagram:

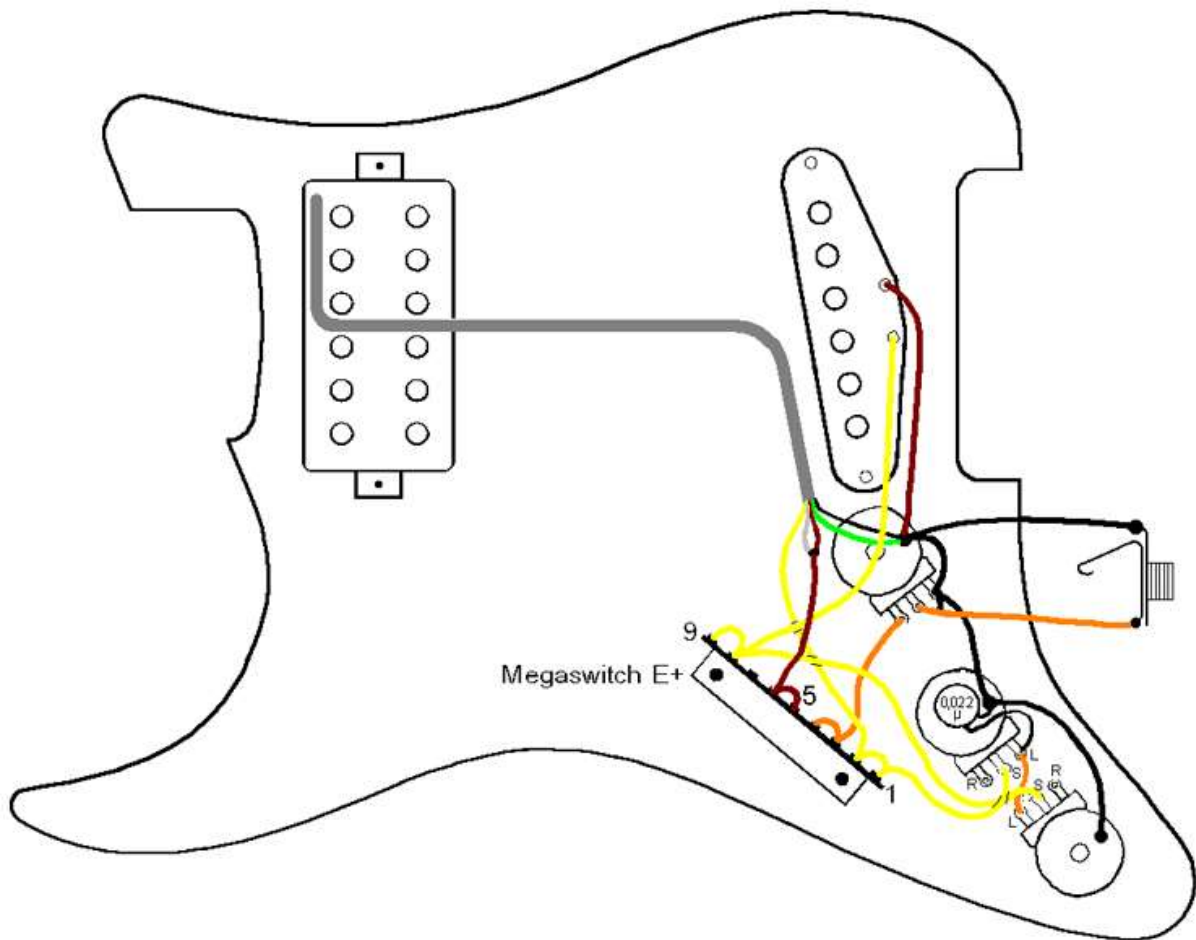

Connections:

Positions

- 1 bridge
- 2 bridge and neck humbucker parallel
- 3 bridge and neck outer coil parallel
- 4 neck outer coil
- 5 neck humbucker

Connections

- 1 to 2, neck hot wire inner coil
- 2 to 1, neck hot wire inner coil
- 3 to 4, output
- 4 to 3, output
- 5 to 6, neck cold wire inner coil and hot wire outer coil
- 6 to 5, neck cold wire inner coil and hot wire outer coil
- 7 -
- 8 to 9, bridge hot wire
- 9 to 8, bridge hot wire
- ground: neck cold wire outer coil, bridge cold wire

SH3. Five positions with Humbucker splitting, inner coil, Megaswitch E+

This switching system is for guitars with a single coil on the bridge and a Humbucker on the neck. The Humbucker can be split while the inner coil remains active. The outer coil is short-circuited. The Megaswitch E+ is ideal for this purpose. Position 3 is buzz-free when the magnetic polarity is configured as follows: N-SN or S-NS.

Switching functions:

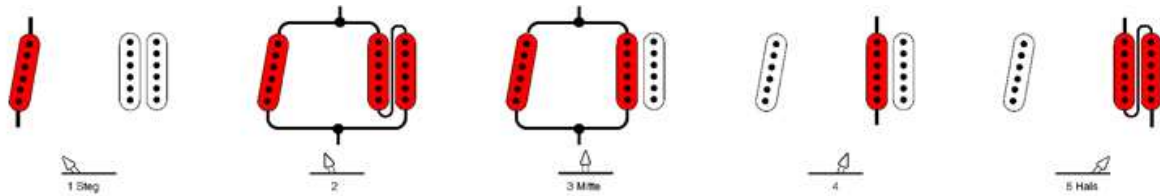

Electrical switching principle:

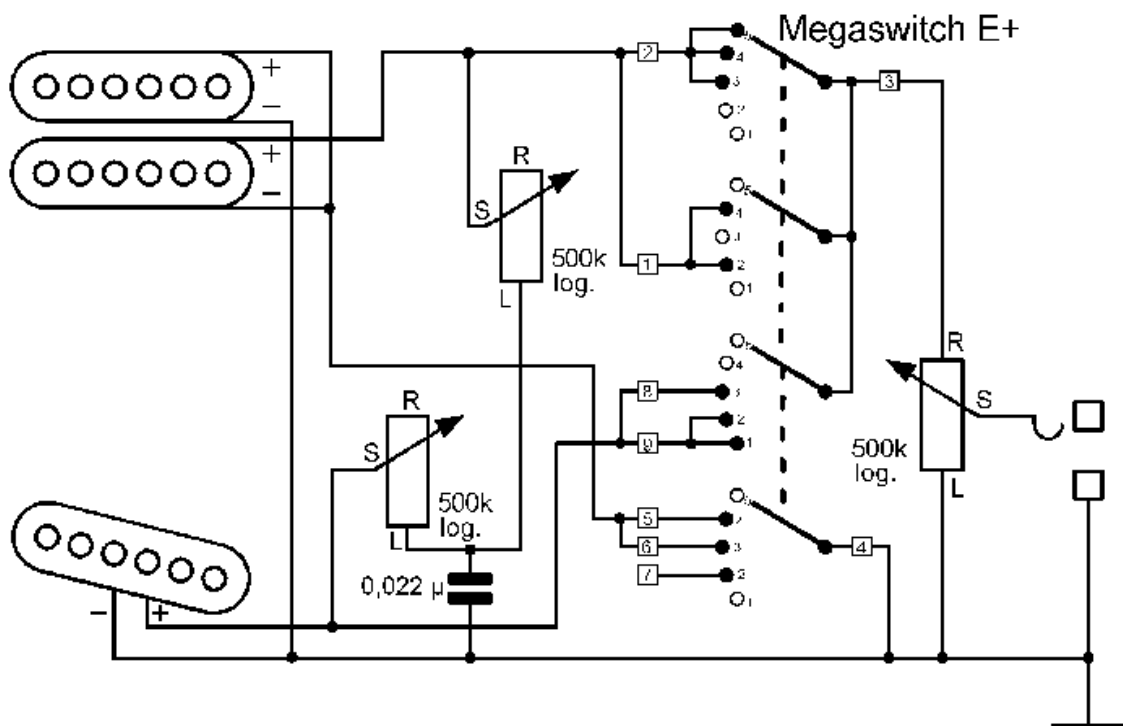

Wiring diagram:

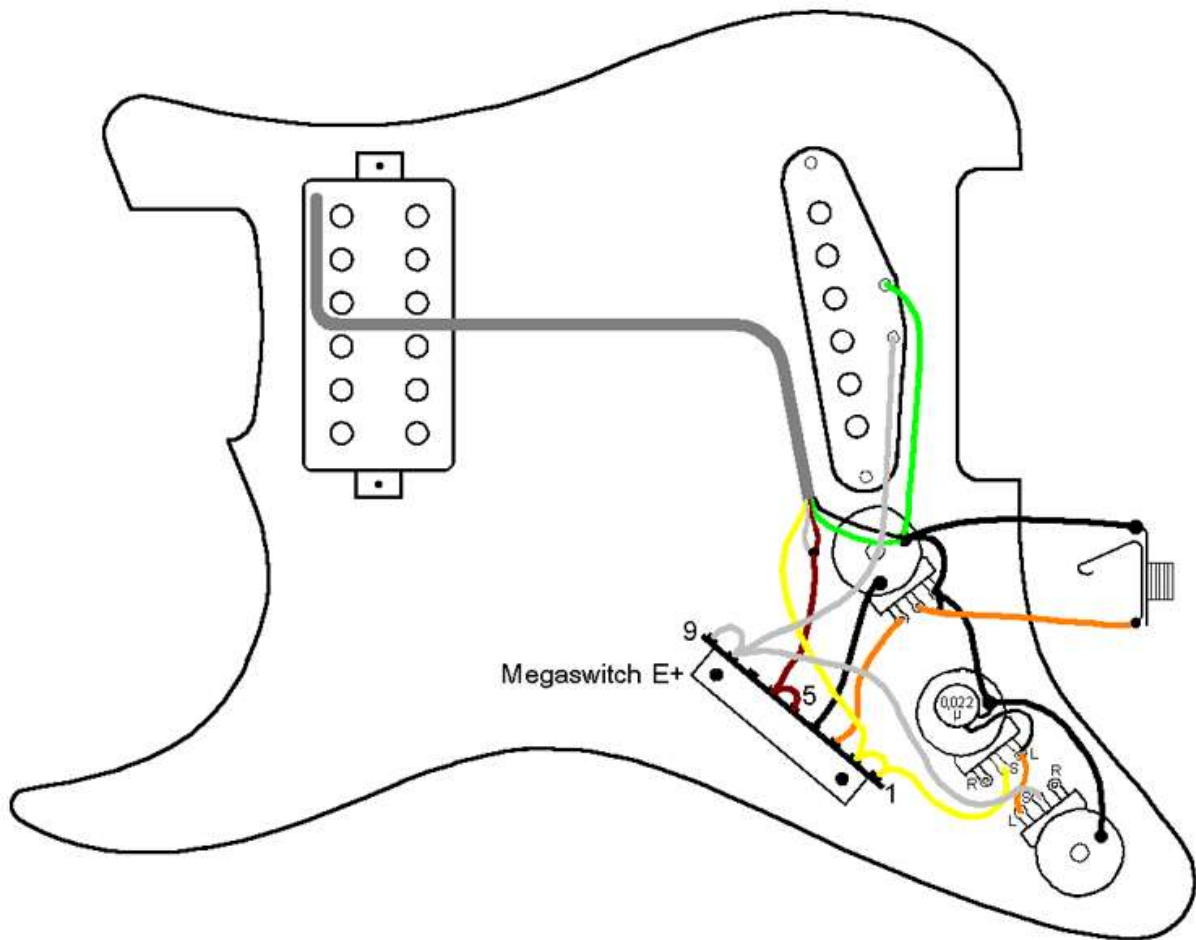

Connections:

Positions

- 1 bridge
- 2 bridge and neck humbucker parallel
- 3 bridge and neck inner coil parallel
- 4 neck inner coil
- 5 neck humbucker

Connections

- 1 to 2, neck hot wire inner coil
- 2 to 1, neck hot wire inner coil
- 3 output
- 4 ground
- 5 to 6, neck cold wire inner coil and hot wire outer coil
- 6 to 5, neck cold wire inner coil and hot wire outer coil
- 7 -
- 8 to 9, bridge hot wire
- 9 to 8, bridge hot wire
- ground: 4, neck cold wire outer coil, bridge cold wire

SH4. Five positions with switching in series, Humbucker splitting, outer coil, Megaswitch M

This switching system is for guitars with a single coil on the bridge and a Humbucker on the neck. It allows both pickups to be switched in series which creates a louder, fuller tone. The Humbucker can be split while the outer coil remains active. The inner coil is short-circuited.

The Humbucker can be split while the outer coil remains active. The inner coil is short-circuited. The Megaswitch M is ideal for this purpose. If a buzz-free sound is required in position, the following magnetic polarity (from the bridge to the neck) is required: N-NS or S-SN.

Switching functions:

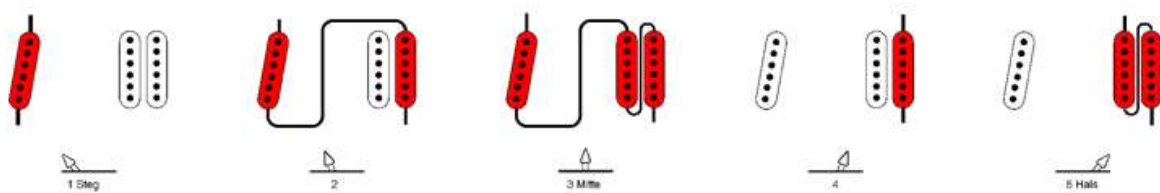

Electrical switching principle:

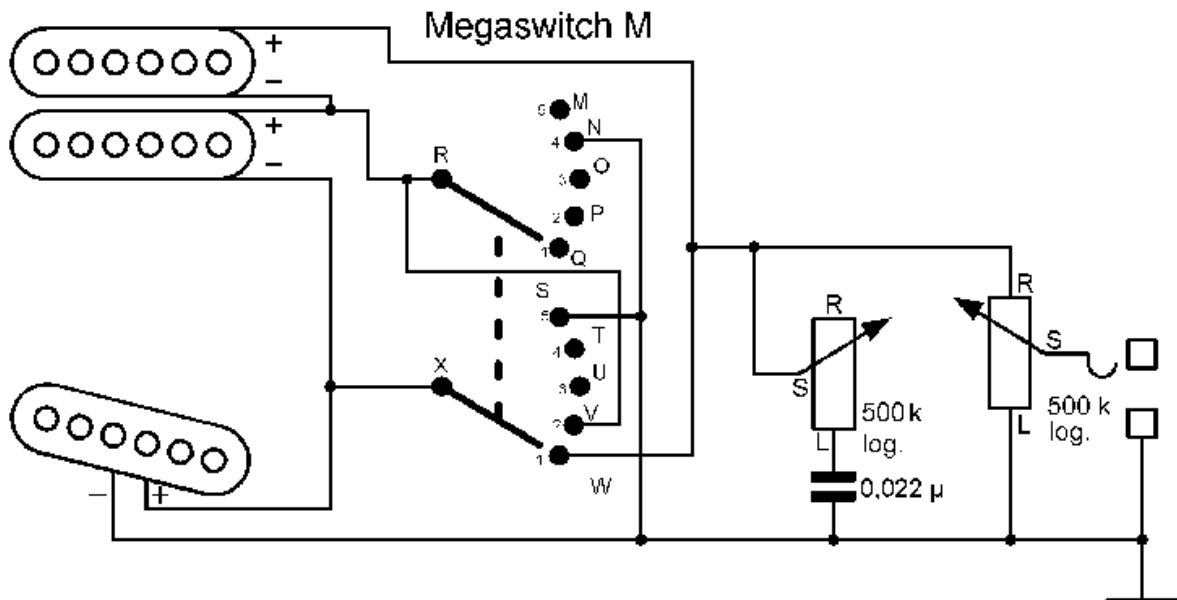

Wiring diagram:

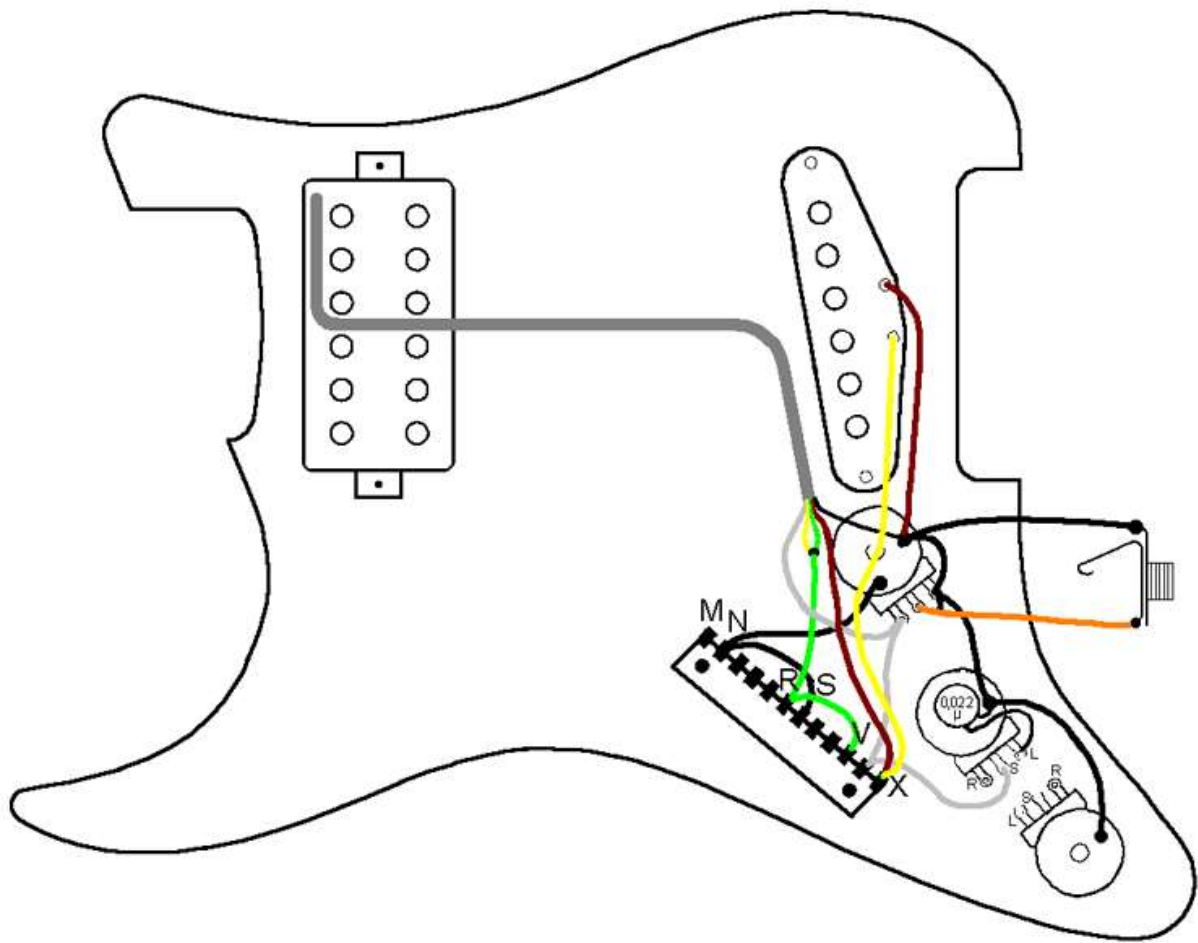

Connections:

Positions

- 1 bridge
- 2 bridge and neck outer coil in series
- 3 bridge and neck humbucker in series
- 4 neck outer coil
- 5 neck humbucker

Connections

M -

N to S and ground

O -

P -

Q -

R to V, neck cold wire outer coil and hot wire inner coil

S to N and ground

T -

U -

V to R, neck cold wire outer coil and hot wire inner coil

W -

X bridge hot wire and neck cold wire inner coil

ground: N, S, bridge cold wire

SH5. Five positions with switching in series, Humbucker splitting, inner coil, Megaswitch M

This switching system is for guitars with a single coil on the bridge and a Humbucker on the neck. It allows both pickups to be switched in series which creates a louder, fuller tone. The Humbucker can be split while the inner coil remains active. The outer coil is short-circuited.

The Megaswitch M is ideal for this purpose. If a buzz-free sound is required in position 2, the following magnetic polarity is required: N-SN or S-NS.

Switching functions:

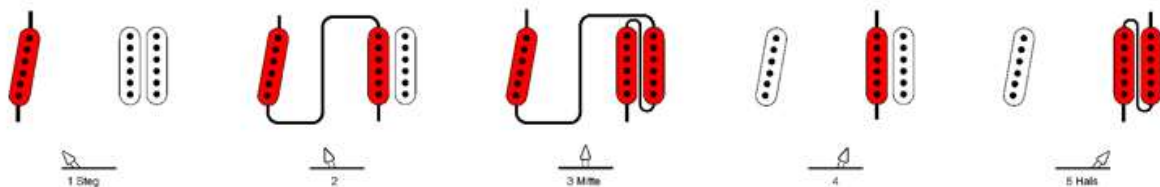

Electrical switching principle:

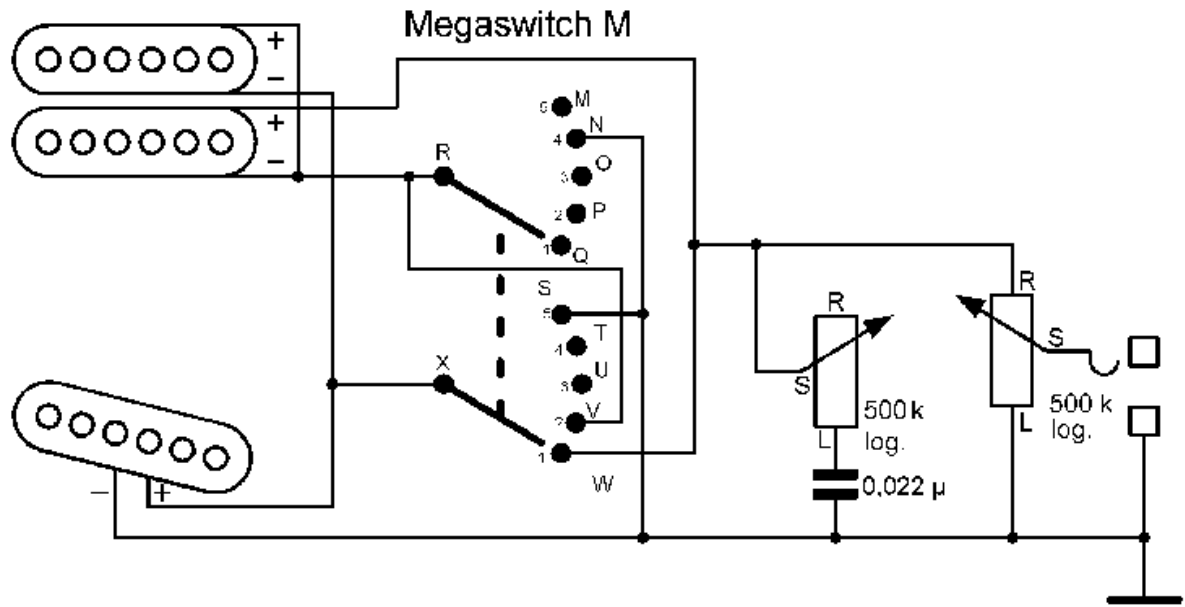

Wiring diagram:

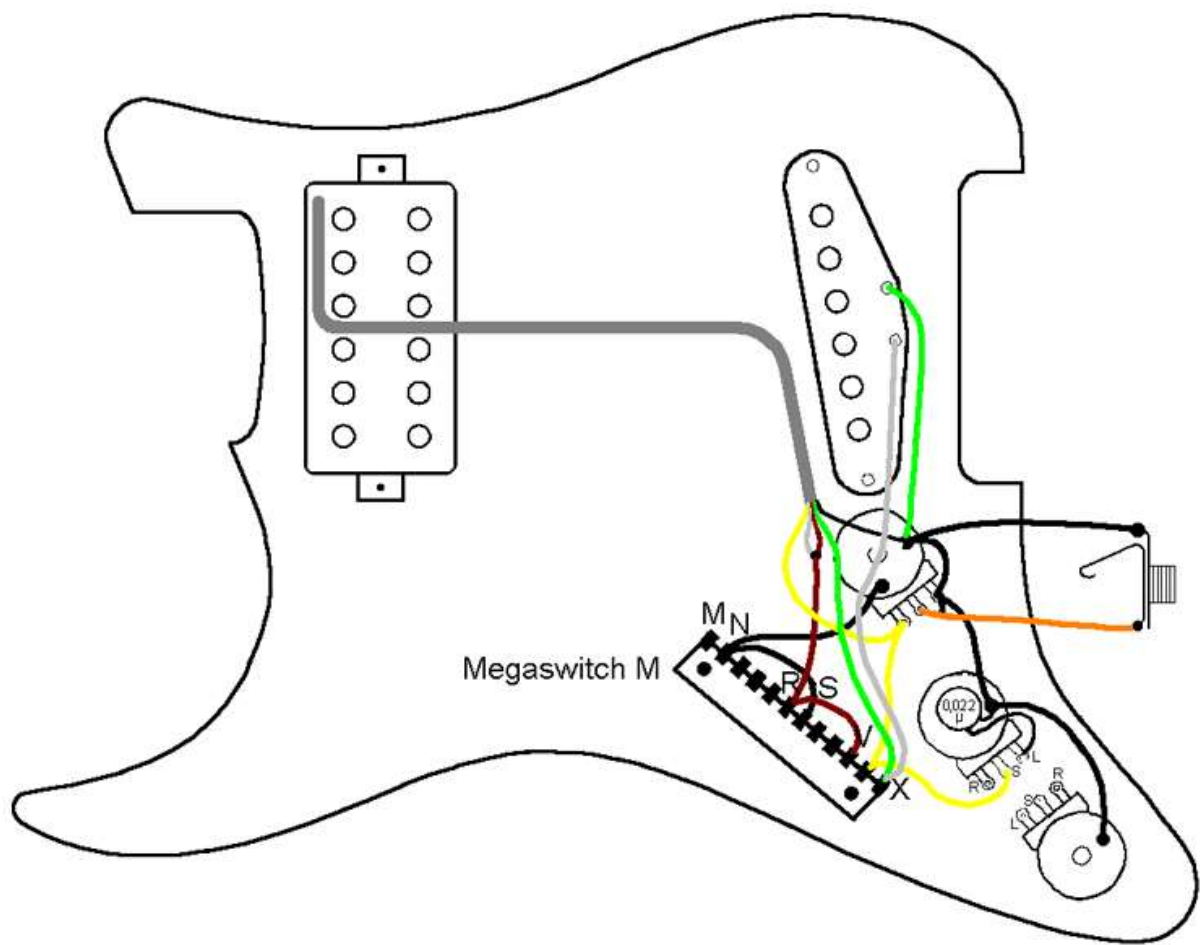

Connections:

Positions

- 1 bridge
- 2 bridge and neck inner coil in series
- 3 bridge and neck humbucker in series
- 4 neck inner coil
- 5 neck humbucker

Connections

- M -
- N to S and ground
- O -
- P -
- Q -
- R to V, neck cold wire inner coil and hot wire outer coil
- S to N and ground
- T -
- U -
- V to R, neck cold wire inner coil and hot wire outer coil
- W -
- X bridge hot wire and neck cold wire outer coil